

NEW

PEDROLLO[®]
... the spring of life



EASY PRO[®]

**Electronic pressure and flow meter/switch
for the control and protection of electrical pumps**

EASY PRO® s an electronic device for the control and protection of pumps used in:

- Domestic water pressurization
- Civil water plants
- Garden water distribution



The electronic **EASY PRO**® starts and stops the pump to which it is fitted as and when required.

It substitutes traditional pressure switch/surge tank systems while offering several important advantages such as:

- **reduced dimensions;**
- **constant flow;**
- **pump protection;**
- **selectable start-up pressure.**



The electronic **EASY PRO**® monitors the pressure and flow rate within the system and protects the pump against dangerous working conditions such as dry running.

When a tap is opened it starts the pump and keeps it running, delivering constant flow, even at low flow rates.

It stops the pump when the flow rate demanded nears zero (2-3 l/min).



The **EASY PRO**® series differs from traditional pressure-flow regulators thanks to several innovative characteristics such as:

- **the BUILT-IN SURGE TANK;**
- **the possibility to SELECT the running (start-up) pressure of the pump;**
- **the back-lit LCD which indicates the pressure and other useful information;**
- **protection against over-currents.**

Pump start-up pressure

EASY PRO® makes it possible to SELECT a pump start-up pressure between 1 and 5 bar. The pressure selection is made using the command button and the instructions that appear on the back-lit LCD screen located on the external cover. A single model is capable of covering a wide range of installation requirements.

Body with built-in check valve

The sturdy, techno polymer body is suitable for use in drinking water distribution systems:

The extremely low pressure losses allow for its use in combination with pumps with flow rates up to 200 l/min.

The special nonreturn valve permits the pump to run even at low flow rates (2-3 l/min) and allows for EASY PRO® to be installed in any position.

Threaded connections

The 1" (ISO 228/1) male threaded connections are also available in "NPT" versions.

Ease of use

A single button, 2 LEDs and the LCD screen facilitate configuration and make it possible to monitor the state of the pump during operation (power on/off / alarm / pressure).



EASY PRO

Electronic

Surge tank

Its substantial accumulation volume and ability to absorb over pressure, a typical characteristic of surge tanks, permit it to be used in installations where other pressure-flow regulators may prove inadequate.

In order to guarantee optimum protection and accumulation performance, the tank pressure, preset at 1.8 bar, may be easily adjusted in function of the selected start-up pressure.

The integrated tank on the EASY PRO® body, as well as reducing the dimensions, simplifies the installation process and removes the laborious and expensive task of installing union tees, as is the case when installing small expansion tanks with seemingly cheaper pressure-flow regulators that do not incorporate an accumulator.



Pressure Indicator

EASY PRO® comes fitted with a sturdy and reliable pressure sensor connected to the circuit board and LCD screen.

During operation the pressure is indicated clearly and accurately on the LCD screen.

In order to guarantee IP65 class electrical protection, the pressure sensor is housed in a separate area, isolated from the circuit board and the other electrical components.



Three-piece joint

In order to simplify the installation process, EASY PRO® can be supplied with a special built-in three-piece joint on request.

Circuit board

Easy to replace and available in versions with:

- **voltage: 220 V / 110 V;**
- **frequency: 50 Hz / 60 Hz;**
- **current: 16 A.**

Housed in a IP 65 class case, it is easily accessible for wiring purposes and is resin bonded in order to assure complete protection against moisture.

The microprocessor protects the pump against:

- **dry running** (guaranteeing automatic restart);
- **excessively frequent starting;**
- **overcurrents.**

The circuit board has passed the most stringent EMC tests for Electromagnetic Compatibility (low interference emission and high disturbance immunity) thus assuring reliable operation in any environment.



TECHNICAL DATA

- VOLTAGE: 230 V / 110 V
- FREQUENCY: 50-60 Hz
- MAX CURRENT: 16 Amp
- IP PROTECTION: IP 65
- WORKING TEMPERATURE: 0 ÷ 65 °C
- MAX FLOW RATE: 200 l/min
- CONNECTIONS: G 1" (ISO 228-1) (on request "NPT")
- WORKING PRESSURE: 10 Bar
- BURSTING PRESSURE: >40 Bar
- WEIGHT: 1950 g
- PROTECTION AGAINST:
 - dry running (automatic reset)
 - excessively frequent starting
 - overcurrents

PRESSURE LOSSES

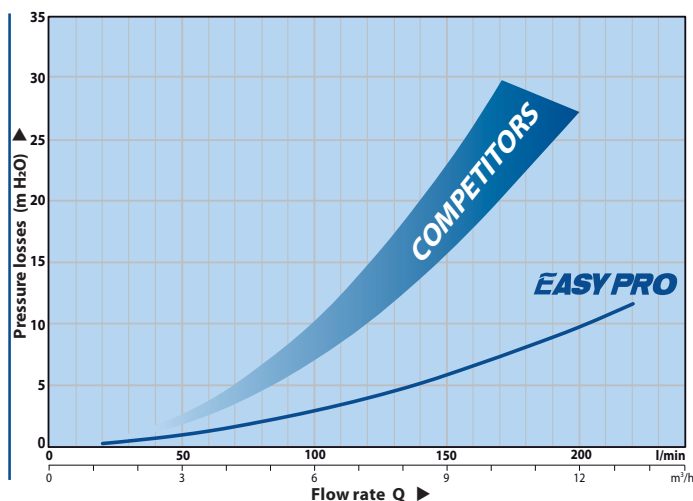

DIMENSIONS

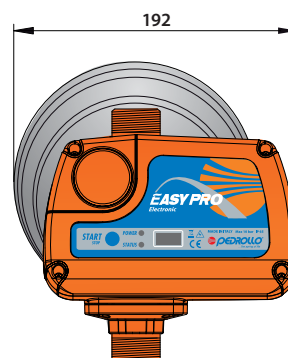
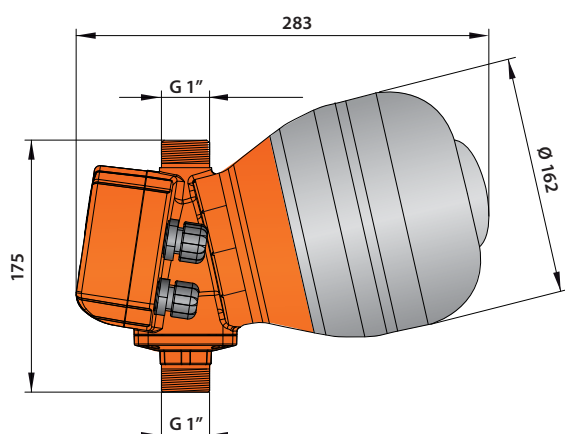

PALLET

14 x 7 = 98 units

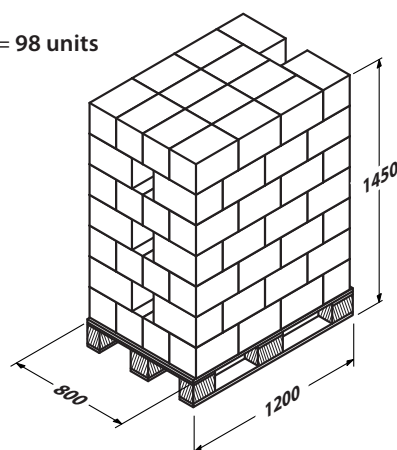

PEDROLLO
... the spring of life

Pedrollo S.p.A. – Via Enrico Fermi, 7 – 37047 – San Bonifacio (Verona) ITALY
tel. +390456136311 – fax +390457614663 – sales@pedrollo.com – www.pedrollo.com